

# Instruction Manual

## Quatro 65

### Construction jig

Art. -No. K565

#### 1. Position gap

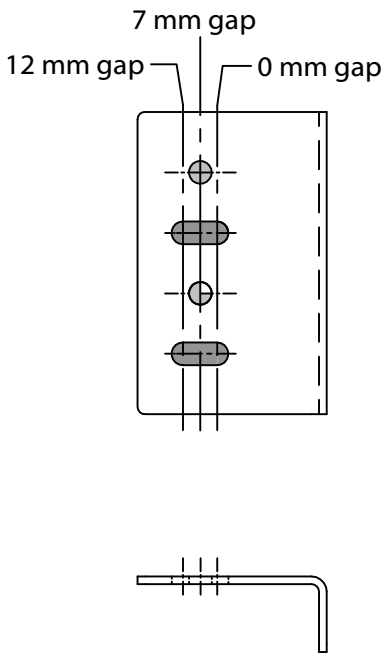

#### 2. Quatro 65 bolt together with angle bracket

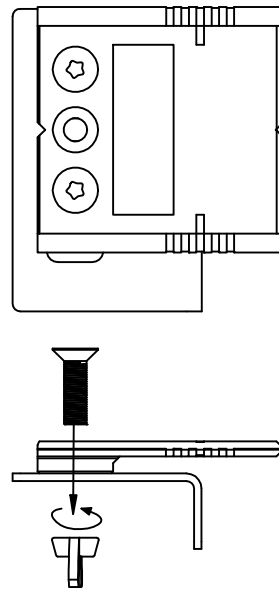

#### 3. Slip Quatro 65 on jig

gap	distance a
0 mm	36 mm
2 mm	32 mm
4 mm	31 mm
6 mm	30 mm
7 mm	30,5 mm
8 mm	29 mm
10 mm	28 mm
12 mm	27 mm

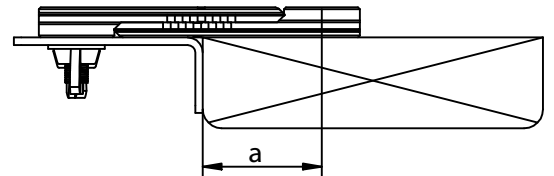

#### 4. Pre-drill Quatro 65 with construction jig and screw on board

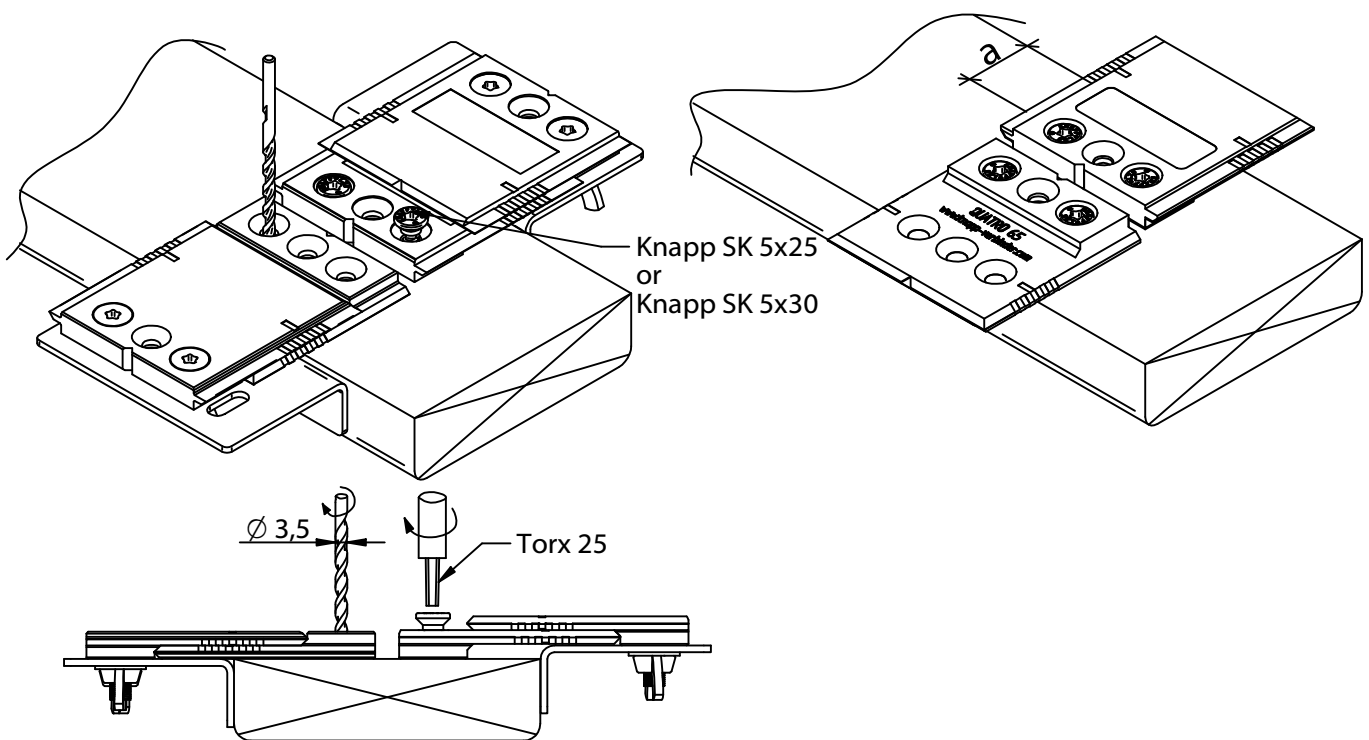

This drawing is the exclusive property of Knapp GmbH.

© Knapp GmbH. All measures in mm - Errors excepted. VERSION 08.09.2014

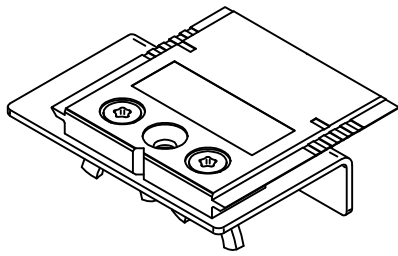

# Notice de montage

## Quatro 65

### Gabarit de montage

Réf. K565

#### 1. Réglage de l'épaisseur du joint

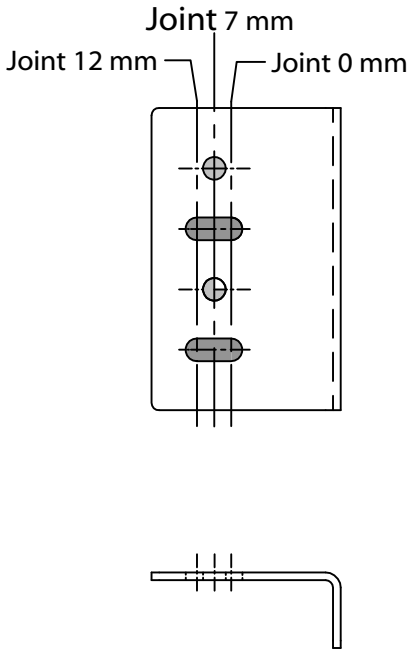

#### 2. Visser Quatro 65 sur la platine

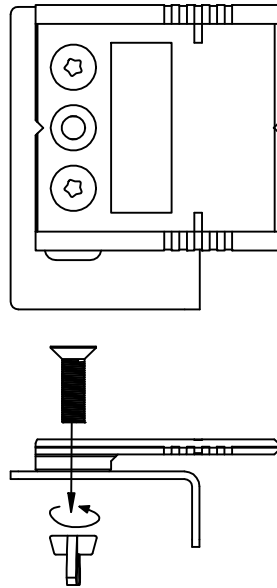

#### 3. Emboîter Quatro 65 dans le gabarit

Joint	Distance a
0 mm	36 mm
2 mm	32 mm
4 mm	31 mm
6 mm	30 mm
7 mm	30,5 mm
8 mm	29 mm
10 mm	28 mm
12 mm	27 mm

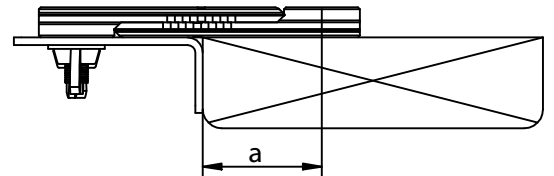

#### 4. Pré-percer + visser Quatro d'un côté et de l'autre à l'inverse

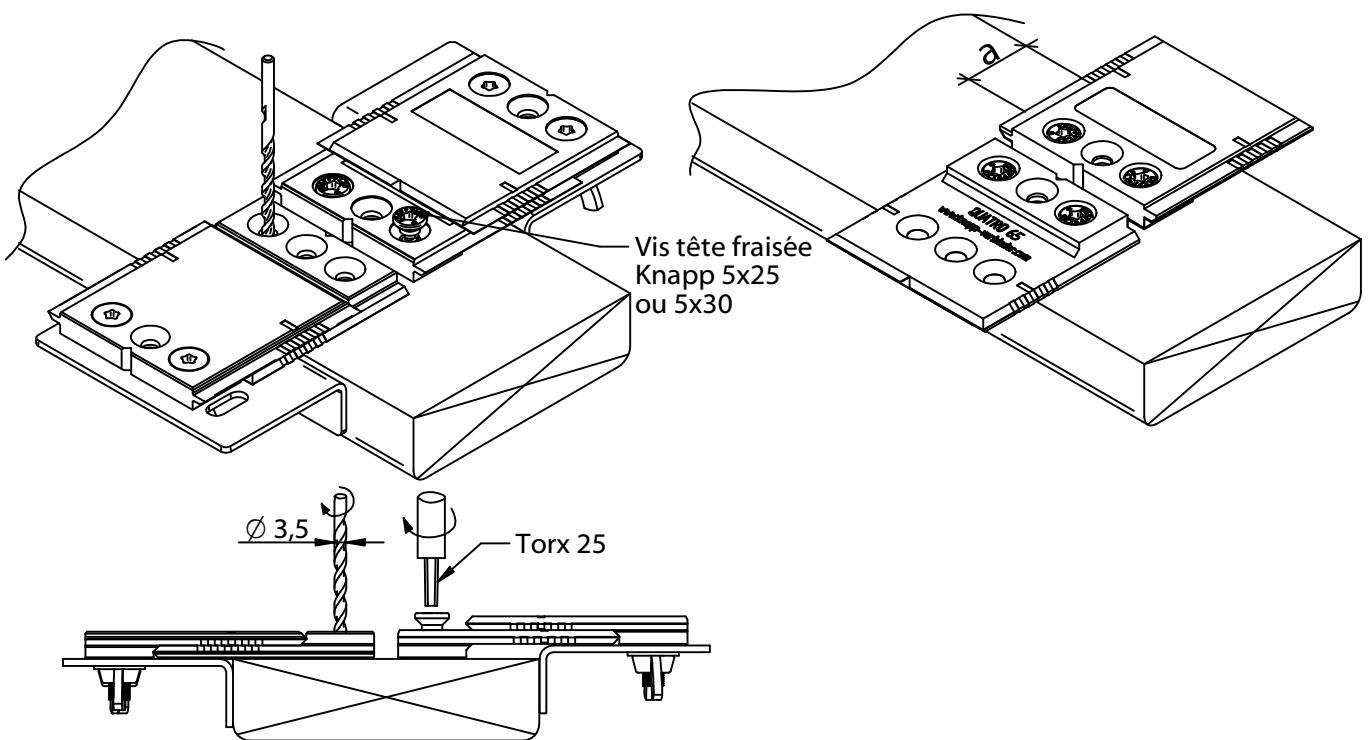

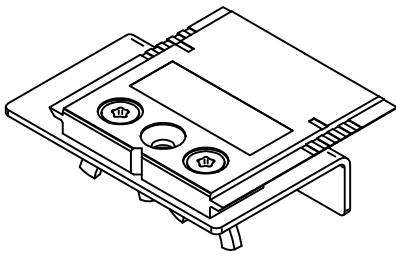

# Montageanleitung

# Quatro 65

# Montageschablone

Art.- Nr. K565

## 1. Fugeneinstellungen

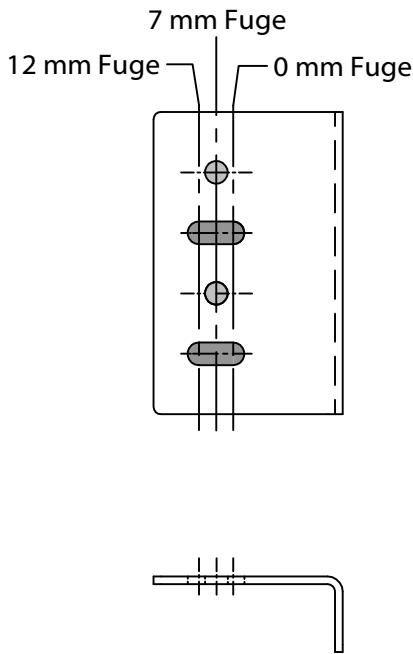

## 2. Quatro 65 mit Winkel verschrauben

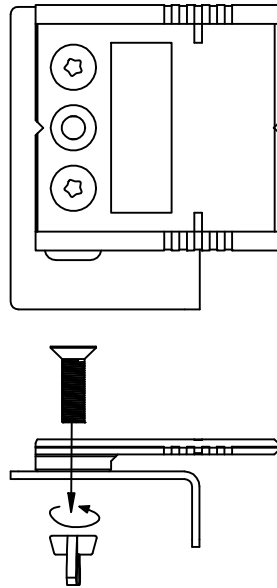

## 3. Quatro 65 auf Schablone stecken

Fuge	Abstand a
0 mm	36 mm
2 mm	32 mm
4 mm	31 mm
6 mm	30 mm
7 mm	30,5 mm
8 mm	29 mm
10 mm	28 mm
12 mm	27 mm

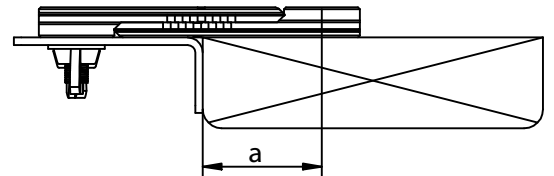

## 4. Quatro vorbohren + wechselseitig verschrauben

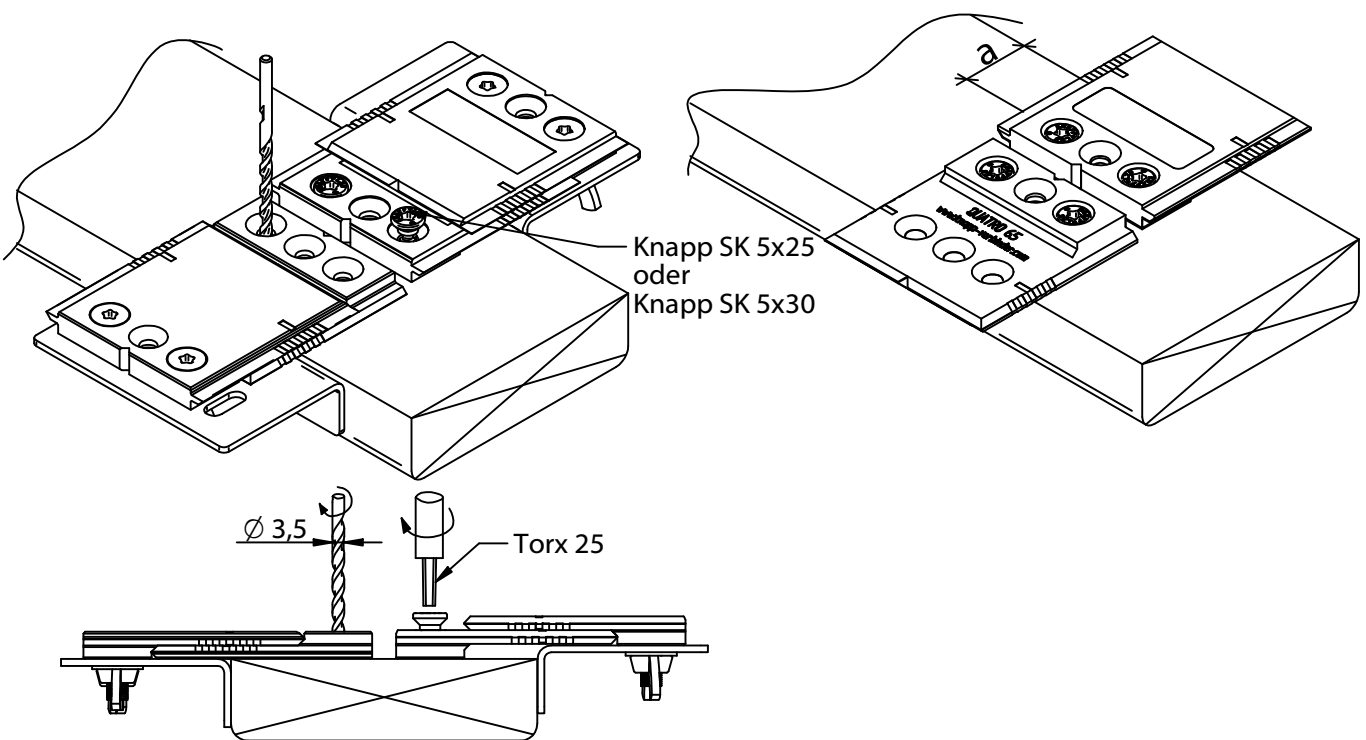

Diese Zeichnung ist Eigentum der Knapp GmbH

© Knapp GmbH. Alle Maße in mm - Irrtümer, Druckfehler und Änderungen vorbehalten / all measures in mm - Errors excepted. VERSION 08.09.2014