



Art.-Nr. K025

Montageanleitung FIXclip GLE20 Plus

Glas- und Profileistenbefestigung

FIXclip GLE20 Plus

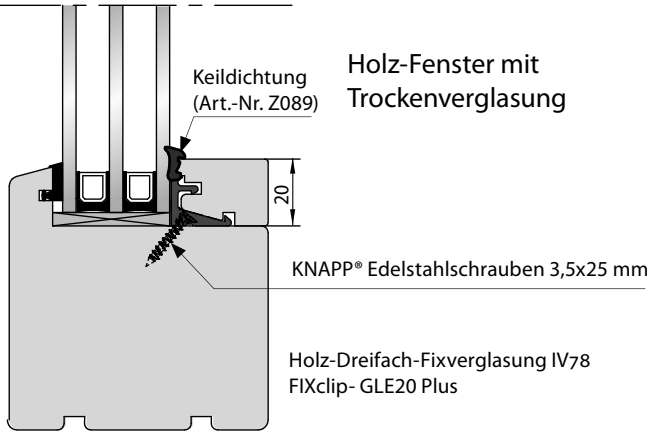
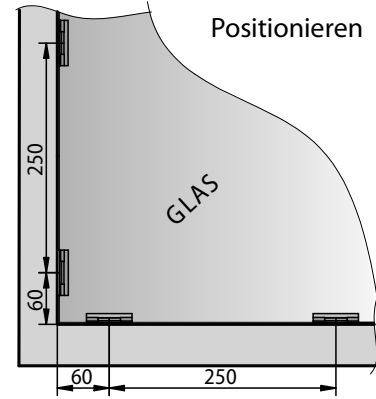
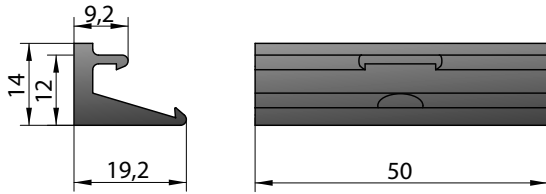

Ausfräsmaße für
angedrückten
Zustand!

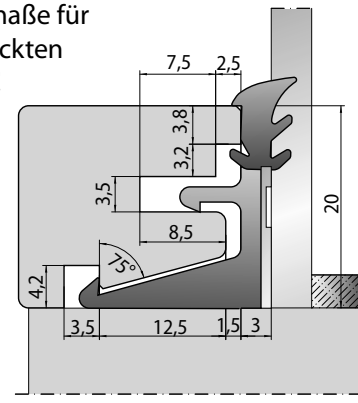

1. Fräsen

KNAPP® FIXclip GLE20 Profilfräsmesser (Art.-Nr. K656)
für Universalfräskopf (Art.-Nr. Z092)

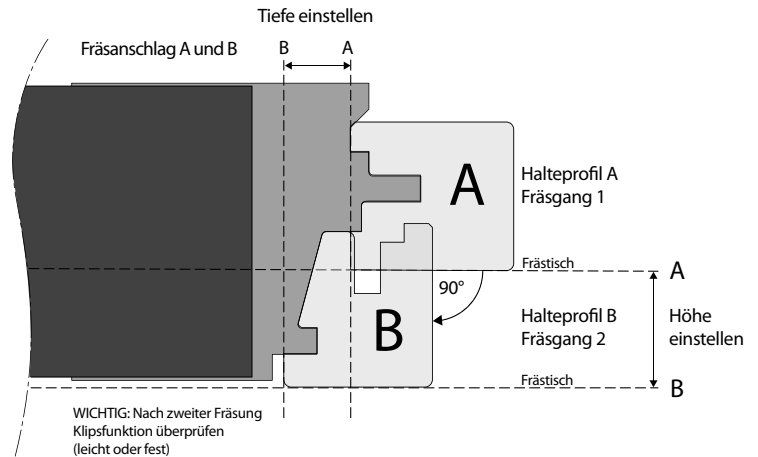

WICHTIG: Nach zweiter Fräsung
Klipsfunktion überprüfen
(leicht oder fest)



2. Glasleisten
zuschneiden



3. FIXclip GLE20
anpressen durch
45° Verschraubung



4. Einclippen der
Glasleiste



5. Keildichtung
einpressen



6. Leichte Verarbeitung
mit Dichtungsroller

FIXclip GLE20 Plus

Glazing bead and profile connector



Art.-No. K025

FIXclip GLE20 Plus

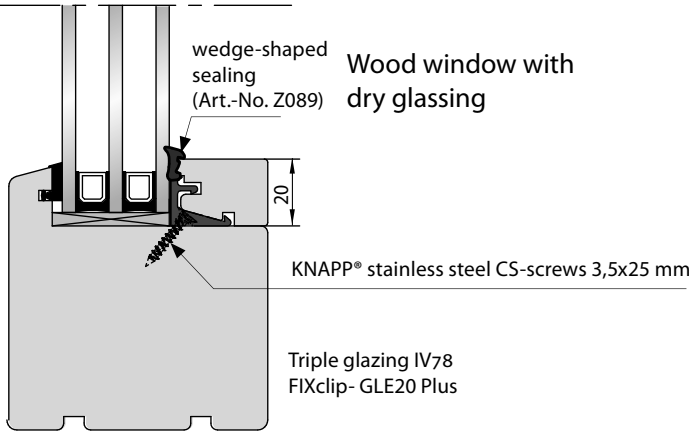
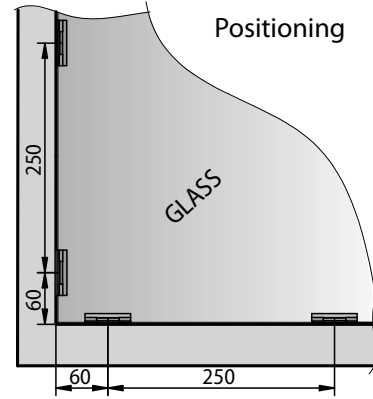
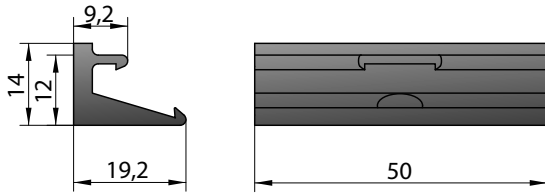

Milling dimensions in fixed position.

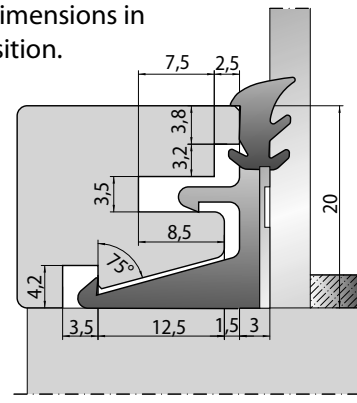

1. Cut grooves

KNAPP® FIXclip GLE20 profile milling knives (Art.-No. K656) for universal milling head (Art.-No. Z092)

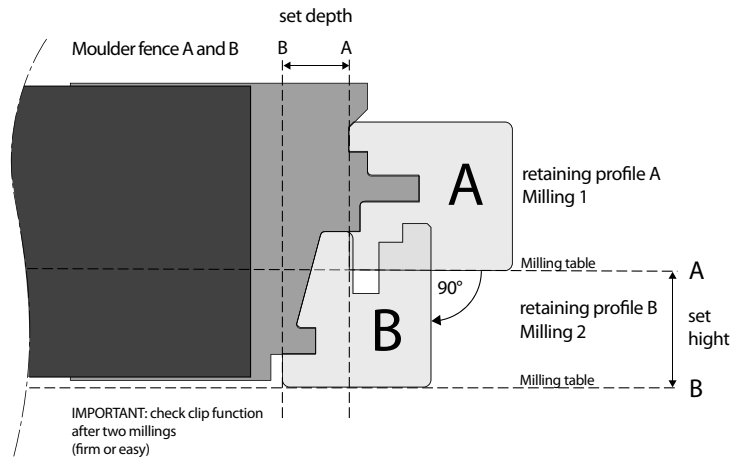

2. Cut to size glass bar



3. Fix FIXclip GLE20 Plus and set pressure with 45° slanted screws

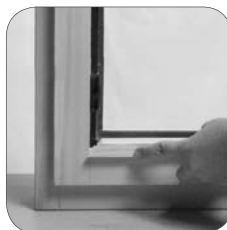

4. Snap in glazing bead



5. Press in wedge-shaped sealing



6. Clean finish with usual sealing roller

This drawing is the exclusive property of Knapp GmbH.

© Knapp GmbH. All measures in mm – Errors excepted. VERSION 1 10.11.2016



Réf. K025

FIXclip GLE20 Plus

Fixation pour parclose

FIXclip GLE20 Plus

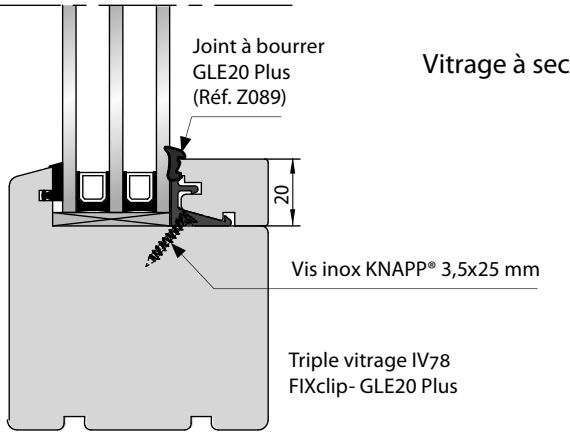
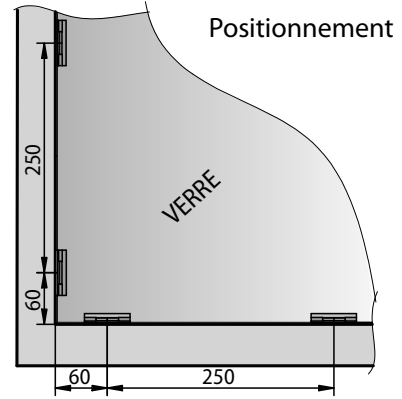
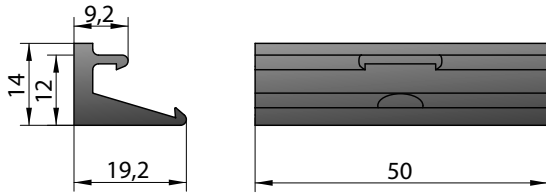

Dimensions d'usinage avec joint à bourrer !

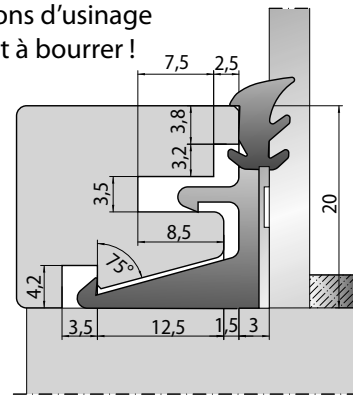

1. Fraiser

Fers pour profilé FIXclip GLE20 (Réf. K656) à monter sur porte ouvert (Réf. Z092)

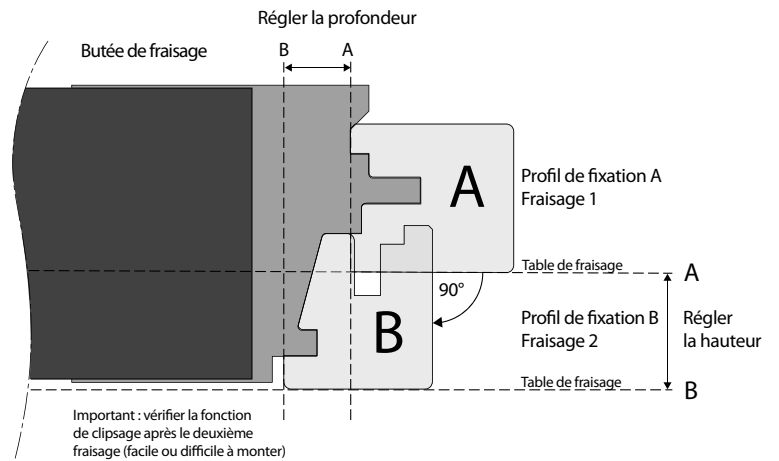

2. Couper barre de verre



3. Visser FIXclip GLE20 Plus 45°



4. Clipser la parclose



5. Bourrer le joint



6. Engagement facile avec une roulette

