

#11.550 - Angled Railbolt

SPECIFICATION

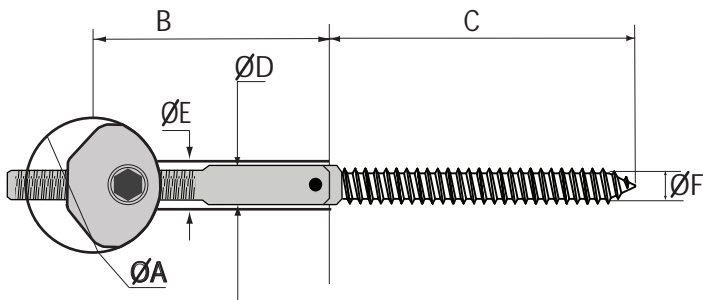

SHAFT CENTRE CALCULATION

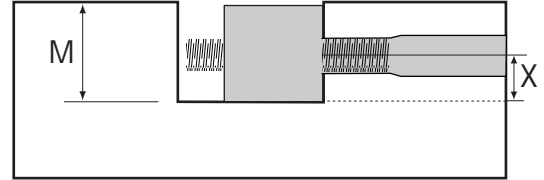

M= Minimum Bore Depth 20mm (51/64 inches)
X = Shaft Centre 10mm (25/64 inches)

Measurements

	Millimitres	Inches
A	25	1
B	+/- 60	+/- 2 ²³ / ₆₄
C	60	+/- 2 ²³ / ₆₄
D	8	⁵ / ₁₆
E	9	²³ / ₆₄
F	6.5 - 7	¹ / ₄



Measurement B will vary as it is determined by the depth and the angle

