

INSTALLATION INSTRUCTIONS

XT POST ANCHOR (17.800)

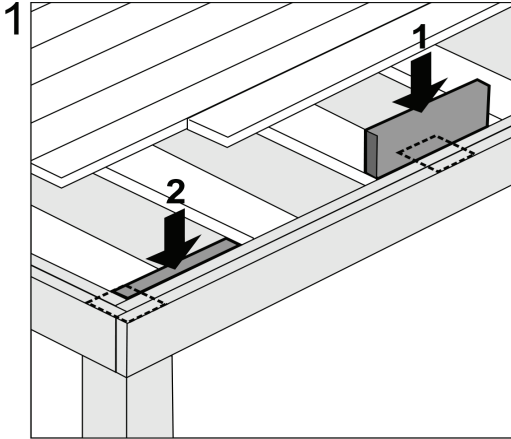

1. Add additional blocking as needed to accept **all four screws and center lag screw**.

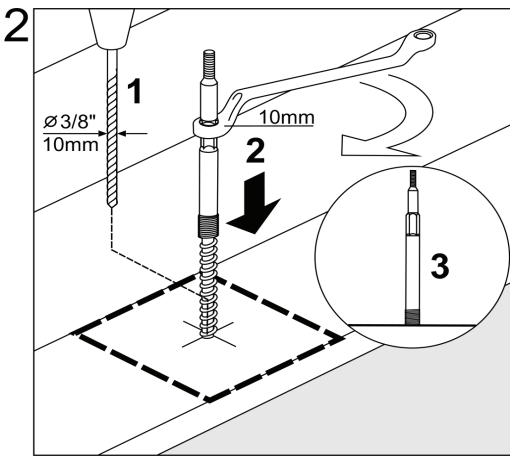

2. Bore the center pilot hole 3/8"-10mm. Tighten lag end into the wood with 10mm wrench stopping at the point of the machine thread that will receive the Base Plate. If needed, use some wax for lubrication on the lag portion of shaft to ease installation.

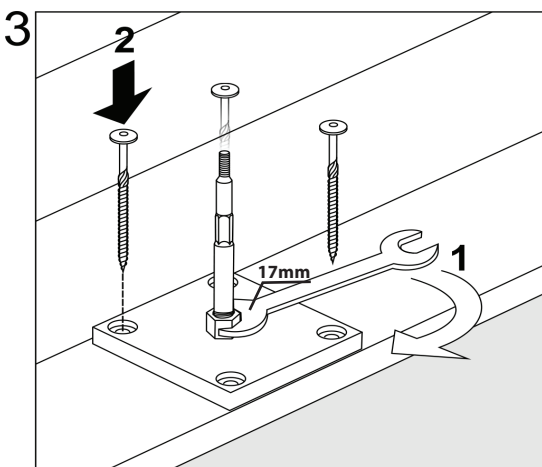

3. Slide the Base Plate over the shaft. Tighten clockwise until it reaches the decking with 17 mm wrench to desired position. Install the 4 screws. (For maximum strength, **ALL SCREWS SHOULD BE INSTALLED**)

(Can be installed into larger posts by routing base plate into post)

Tools needed:

Paddle/spade bits, 3/8"-10mm, 1 1/2"-38mm,
1"-25mm, 5/8"-16mm,
17mm wrench/spanner,
10mm ring wrench/spanner

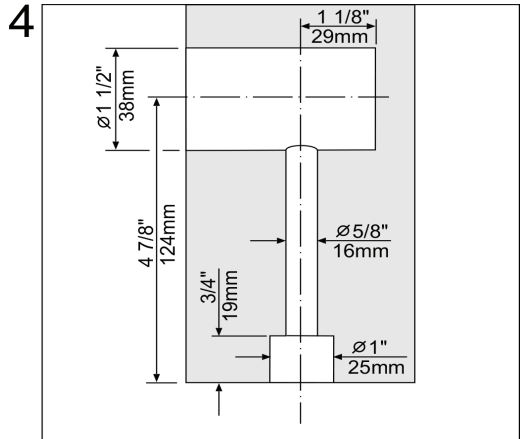

4. Mark the center point of the 1 1/2"-38mm hole on side of the post and bore to recommended depth. Mark the center of the post base and bore the 1"-25mm hole 3/4"-19mm deep. Now using a 5/8"-16mm continue boring through the centre of the 1"-25mm hole until reaching the 1 1/2"-38mm hole. Ream the 5/8"-16mm hole if necessary. The 1"-25mm hole allows the post to sit freely over the hex nut on the Base Plate.

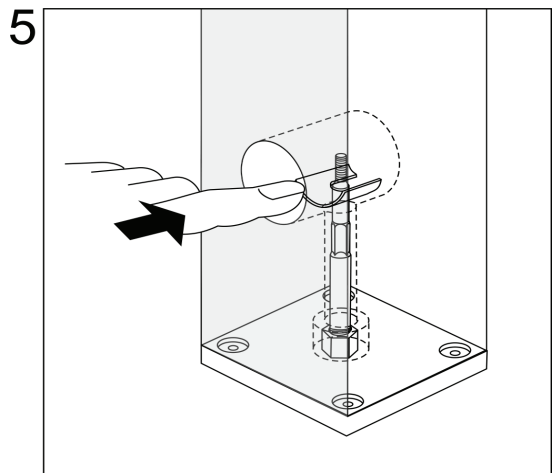

5. Position post over screw shaft and slide the curved washer making sure it is pushed to the to the very end around the screw shaft.

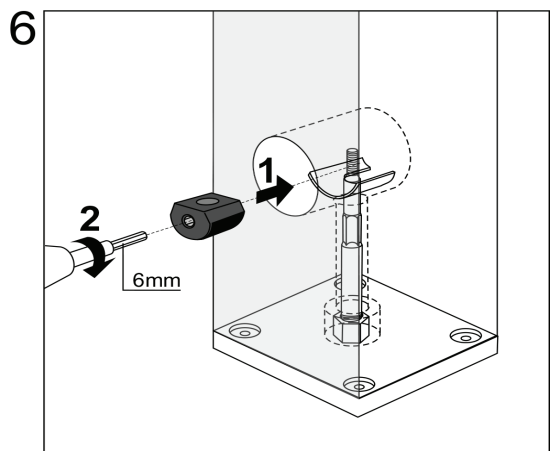

6. Finally install the gear housing onto the screw shaft, tighten using a 6mm hex bit (provided) in a power or hand tool. Finish off with a wood plug (not included) as needed or slide post cover over wood post at this point.