



<sup>®</sup>  
**D** FAST 10  
**Y** FAST 14  
**L** LOCK 14

**Plug connector**

- 
- 
- 
- 
- 
- 
- 

patented by  
**KNAPP®**

**LOCK'N FAST!**

Innovative – Clever – Connect

**KNAPP®**  
connectors.com

## FIYU® FAST 10



## FIYU® FAST 14

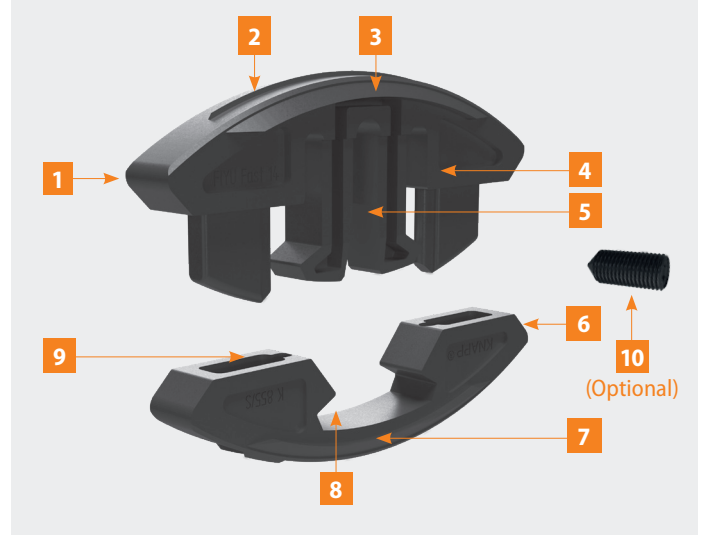

- 1** FIYU® FAST - Expanding Lamella
- 2** Fixing edge
- 3** Cutting edges
- 4** Guide pin
- 5** Spring hook
- 6** FIYU® FAST – Clamping Lamella
- 7** Cutting edges
- 8** Spring hook holder
- 9** Slots for guide pins
- 10** Socket Set Screw (optional)

### System Advantages:

- ▮ Plug-in connector designed for tongue-and-groove joints, ensuring immediate and stable hold
- ▮ No suspension and mounting path required
- ▮ Compact and precise guidance
- ▮ Can be processed manually and industrially
- ▮ Flush pre-assembled design for optimal stackability
- ▮ Easy to dismantle when needed
- ▮ Provides high clamping force with 100% fitting accuracy
- ▮ Supports high load capacities
- ▮ Can be loaded from two directions
- ▮ Self-locking mechanism for added security

## FIYU® FAST Plug Connector

Tongue and groove connectors for furniture and interior fittings

FIYU® FAST – now available in two sizes (size 14 and size 10) – are self-tensioning furniture connectors that securely or flexibly connect miters and 90° corners. They can also be used as a gluing aid. FIYU® FAST size 10 can additionally be used as a middle wall connector and shelf support for materials with a thickness of 12mm | 1/2 inch or more.



Connector for 90° miter joints

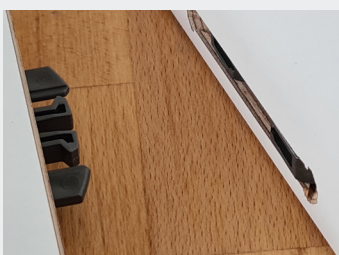

Plug-in connector



## FIYU® LOCK 14



### System Advantages:

- ! Suitable for materials with a thickness of 16 mm or more
- ! Allows subsequent installation of shelves as supports and guide aids
- ! Flexible assembly sequence
- ! Quick and easy disassembly
- ! Mechanically lockable for added security
- ! Can be used as a one-piece or two-piece fastening solution

- 1 FIYU® LOCK – Spring Lamella
- 2 Cutting edges
- 3 Spring (3.6 mm)
- 4 Hole for optional fixation
- 5 Slot for the spring lamella
- 6 FIYU® LOCK – Slotted Lamella
- 7 Tensioning Screw M5x13 mm (optional)

## FIYU® LOCK Plug Connector

Tongue and groove connectors for furniture and interior fittings

FIYU® connectors with cutting edges are designed for precision— their well-thought-out design ensures secure and exceptionally fast connections for countless applications. For subsequent shelf installation, the FIYU® LOCK (single part) cuts into the material and secures itself, saving both time and costs. Optionally, the connector can be fixed with a screw.



Up to 90° miter and corner joints



Subsequent shelf installation



## Machine Recommendation

All FIYU® connectors can be processed with a CNC machine, ensuring significant time savings in the production and assembly of components.

For special on-site adjustments, a flat dowel milling machine can also be used.



## FIYU® FAST 10

### Processing

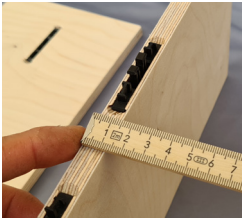

FIYU® FAST 14 can be used as a center panel shelf connector with panel thicknesses of 12 mm or more.

1 Install in pre-milled grooves opposite each other.

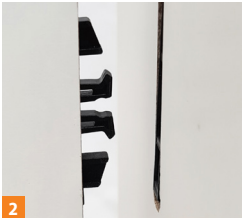

2 Position the connector (do not offset installation).

3 Plug connectors together.



4 Connect components with or without adhesive.



## FIYU® FAST P14

### Processing



1 Secure butt joint (90 degrees) with grub screw – assemble at a 45-degree miter with or without adhesive.



2 If required, secure the miter at 45 degrees with a grub screw



3 Corner joint mitered at 45 degrees (gluing aid).

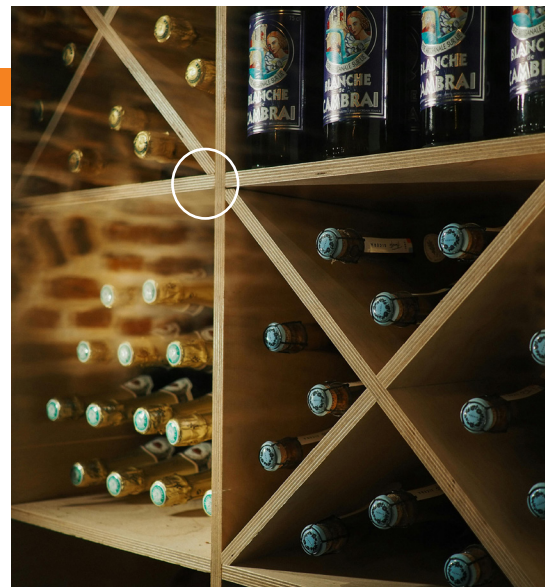

**Application:** Suitable for carcass parts, intermediate shelves, and retrofitting shelves as shelf supports. Can also be used for panels, claddings, covers, and profile strips for plug-in assembly.

**Advantages:** Concealed, self-tensioning, and dismantlable connectors that can be loaded immediately.

**Choice of Material:** FIYU® LOCK 14: Compatible with all wood, wood-based, and plastic materials with a minimum thickness of 16 mm.  
FIYU® FAST 10: Suitable for all softwood and board materials with a minimum thickness of 12 mm.

**Processing:** Can be processed using CNC routers, flat dowel routers with a pendulum groove, and by inserting the push-on and mounting

**Fastening:** Insert the connector flush with the edge without requiring an assembly path and simply join the components together.

**Accessories:** FIYU® grub screw M6x12 mm (for FIYU® FAST 14) | Art. No. Z428  
FIYU® clamping screw M5x13 mm (for FIYU® LOCK 14 and FIYU® FAST 10) | Art. No. K857, ISK 5 with ball head | Art. No. Z647

## Plastic Plug Connector

patented by  
**KNAPP®**

### FIYU® LOCK 14

Item no. K859

= FIYU® LOCK spring lamella + slotted lamella  
Item no. K856/A + Item no. K856/S

+ Tensioning Screw M5x13 mm | Item no. K857



For material thickness starting at  
16mm (5/8 inch)

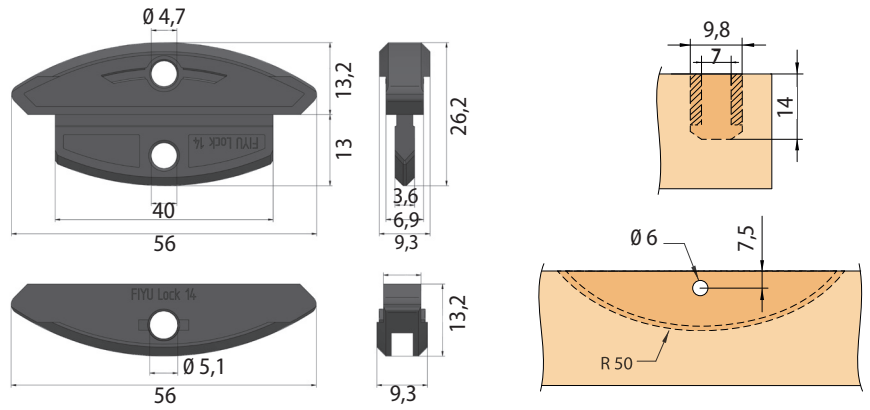

### FIYU® LOCK 14 Male

Item no. K856

= FIYU® LOCK Spring Lamella | Item # K856/S

+ Tensioning Screw M5x13 mm | Item no. K857

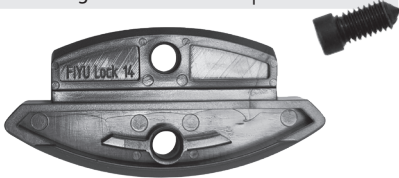

For concealed shelf supports  
For material thickness starting from  
16mm (5/8 inch)

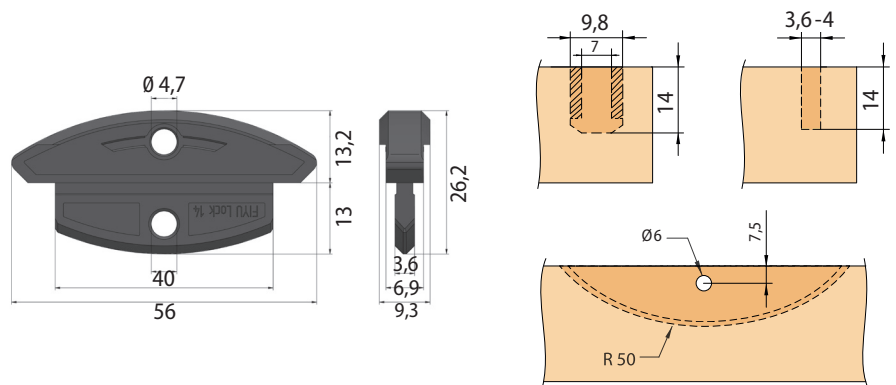

### FIYU® FAST 10

Item no. K860

+ Optional Socket Set Screw M5x13 mm  
| Item no. K857

**NEW**



For 12mm (1/2 inch) material thickness  
For 10 mm milling depth

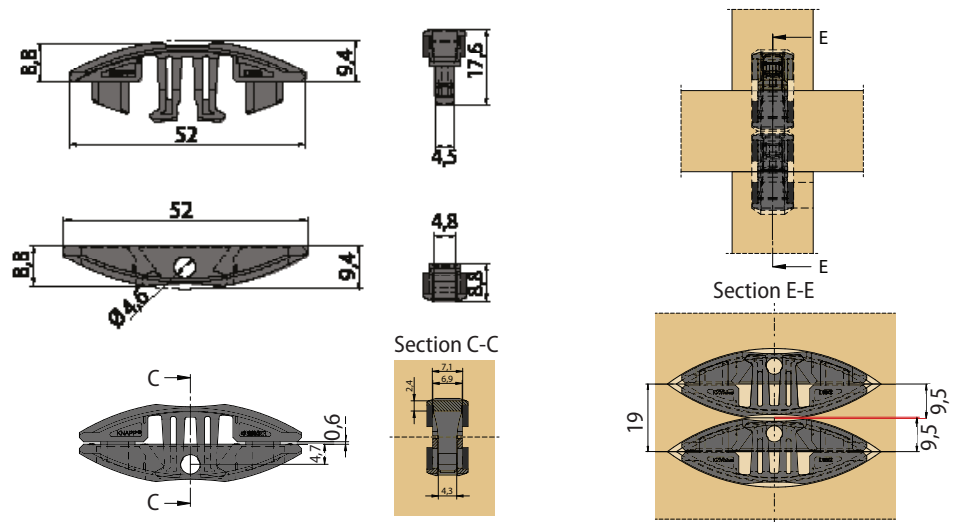

### FIYU® FAST 14

Item no. K855

+ Optional Socket Set Screw M6x12 mm  
| Item no. Z428



For material thickness starting at  
16mm (5/8 inch)

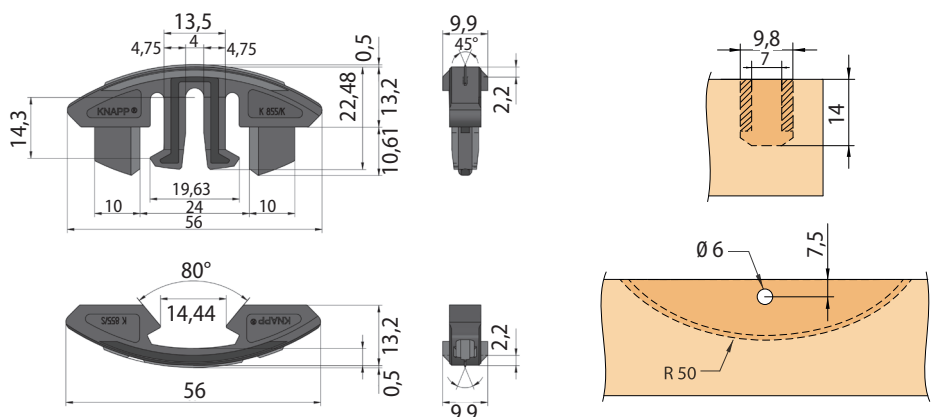

### Plastic Plug Connector

Item no. K058

FIYU® FAST 10

10 mm groove

NEW



Size 10

- Concealed, self-tightening, removable connector, can be loaded immediately.
- Suitable for carcass parts, intermediate shelves, and the retrofitting of shelves as shelf supports and for panels from 12 mm | 1/2 inch.
- Fastening: By radial insertion with cutting edges on both sides.

### Plastic Plug Connector

Item no. K058

FIYU® LOCK 14 – Male

14 mm groove

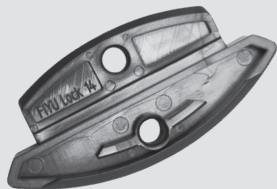

Size 14

- Concealed, self-tightening, removable connector, can be loaded immediately.
- Suitable for carcass parts, intermediate shelves, and the retrofitting of shelves as shelf supports and for panels.
- Fastening: By radial hammering with cutting edges on both sides.

### Plastic Plug Connector

Item no. K855

FIYU® FAST 14

14 mm groove

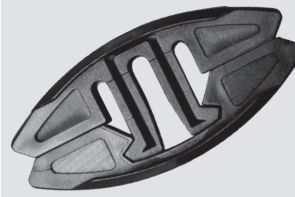

Size 14

- Concealed, plug-in connection on tongue and groove basis for immediate stability and hold.
- Suitable for carcass parts and retrofitting shelves as shelf supports and for panels.
- Fastening: By radial insertion with cutting edges on both sides.

### Plastic Plug Connector

Item no. K058

FIYU® LOCK 14 – Pair

14 mm groove



Size 14

- Concealed, self-tightening, removable connector, can be loaded immediately.
- Suitable for carcass parts, intermediate shelves, and the retrofitting of shelves as shelf supports and for panels.
- Fastening: By radial hammering with cutting edges on both sides.

Find more Knapp connector recommendations for furniture construction at [www.knappconnectors.com](http://www.knappconnectors.com)

### Plastic Plug Connector

Item no. K058

FAST 20

4 mm groove



Size 20

- Concealed, self-tightening, detachable connector, can be loaded immediately.
- Suitable for clip-on panels, claddings, covers, and profile strips.
- Fastening: By radial hammering with cutting edges on both sides and optional bonding.

### Sliding Connector Die-Cast Aluminum & Zinc

Item no. K026

METAL 20

4 mm groove



Size 20

- Concealed, self-tightening, dismountable connector with integrated stop for locking.
- Suitable for carcass furniture and door panels for insertion without clamps, ideal for miter cuts.
- Fastening: By screwing with PH screws.

### Sliding Connector Die-Cast Aluminum & Zinc

Art.-Nr. K049

SILVER 20

4 mm groove



Size 20

- Concealed, self-tightening, dismountable connector with integrated stop for locking, can be loaded immediately.
- Suitable for carcass furniture, gluing aid for miters and corners without clamps.
- Fastening: By radial hammering with cutting edges on both sides.

### Sliding Connector - Glass Fiber Reinforced Plastic

Item no. K023

CHAMP 20

4 mm groove



Size 20

- Concealed, self-locking, detachable connector.
- Perfect for carcass furniture and as a gluing aid for miter joints and corners without clamps.
- Installation: Secured with KNAPP® PU+ adhesive.

### Plastic Sliding Connector

Item no. K053

SUNNY 20

4 mm groove



Size 20

- Concealed, self-locking connector with automatic locking via locking tabs, ready for immediate load-bearing.
- Ideal for carcass furniture, serving as a gluing aid for miters and corners without the need for clamps.
- Installation: Secured by radial hammering with cutting edges on both sides.

### Guiding symbols:

- Wood connection
- Installation from above
- Invisible
- Prefabrication in the workshop
- Flush edge processing
- No clamps required



WEBSITE