

NOTE:
DIMENSIONS SHOWN IN [] ARE IN MM

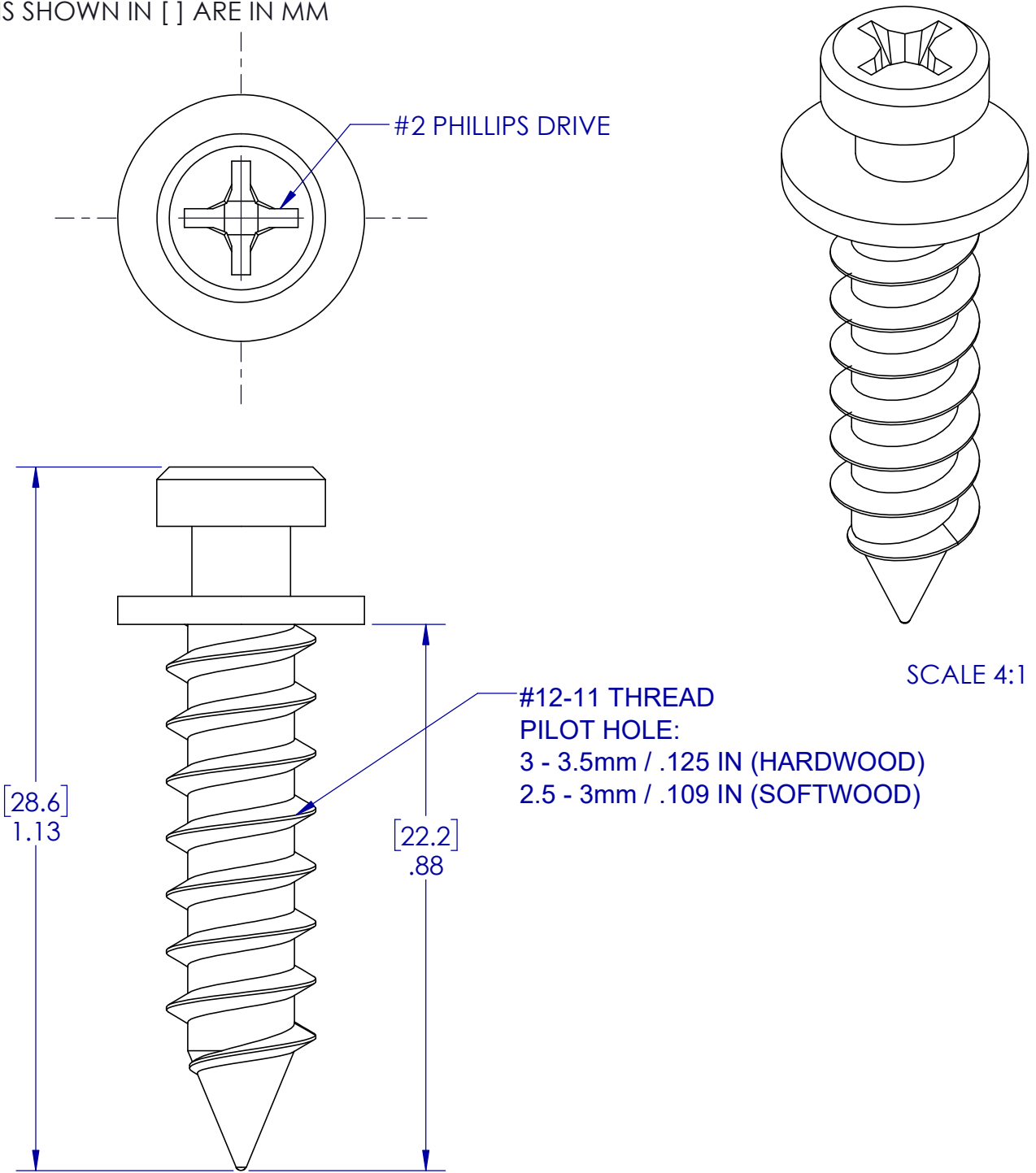

FOR REFERENCE ONLY



THIS DRAWING IS PROPERTY OF:
KNAPP US
12245 NATIONS FORD RD STE 403
PINEVILLE, NC 28134
WWW.KNAPPCONNECTORS.COM

MATERIAL STEEL		PART NAME SHOULDER SCREW #12 SMT X 7/8"	
PART NO. 5070			
DRAWN BY JAB	ISO NO.	SCALE 4:1	REVISION V01

© Knapp GmbH. Alle Maße in mm - Irrtümer, Druckfehler und Änderungen vorbehalten / all measures in mm - Errors excepted. PRINT DATE: LUNES, 30 DE MARZO DE 2026 12:23:16 P. m.